

Model: **KE20 / KES20**

KOHLER POWER SYSTEMS

Diesel

ISO 9001
KOHLER
POWER SYSTEMS
NATIONALLY REGISTERED

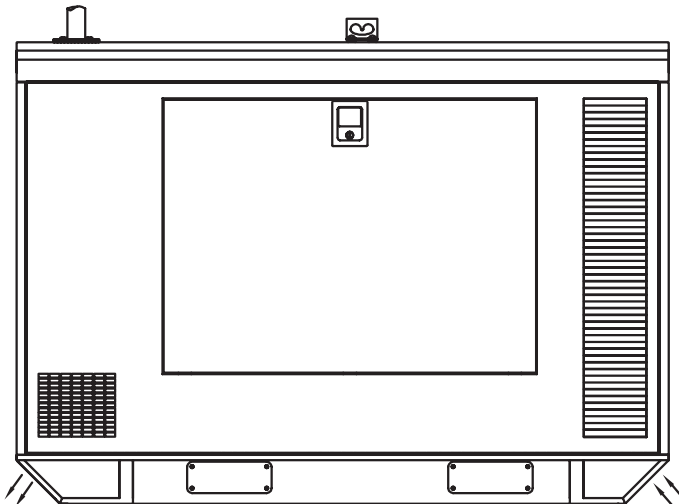

Standard Features

- Kohler Co. provides one-source responsibility for the generating system and accessories.
- The generator set and its components are prototype-tested, factory-built, and production-tested.
- Two-year limited warranty covers all systems and components.
- Industrial diesel engine with 12-volt battery charging alternator.
- Single-bearing alternator with class H insulation.
- Fully Programmable Digital AVR.
- MAUX Winding for Excellent Motor starting capability.
- 50°C (122°F) ambient radiator.
- Subbase fuel tank.
- Vibration isolators.
- Dry type air filter.
- Fuel Water separator.
- Main line breaker.
- Starting battery and cables with inbuilt battery charger.
- CPCB-certified sound enclosure.
- Conveniently located fuel level indication and fuel filling point.
- Single point lifting arrangements.
- Operation and installation literature.

Generator Set Ratings

Genset	Engine	Alternator	Voltage	PH	Hz	Prime Rating	
						kW/kVA	Amps
KE20	G20	ECO 28-1LN/4	240/415	3	50	16/20	28
KES20	G20	ECO 32-2S	240	1	50	16/20	83

PRIME POWER RATINGS: Prime power ratings apply to installations where utility power is unavailable or unreliable. At varying load, the number of generator set operating hours is unlimited. A 10% overload capacity is available for one hour in twelve. Ratings are in accordance with ISO-8528/1, overload power in accordance with ISO-3046/1 and BS 5514. For limited running time and base load ratings, consult the factory. Obtain the technical information bulletin (TIB-101) on ratings guidelines for the complete ratings definitions. The generator set manufacturer reserves the right to change the design or specifications without notice and without any obligation or liability whatsoever.

Alternator Specifications

- Alternator meets BS EN 60034 and the relevant section of other international standards such as BS5000, VDE 0530, NEMA MG1-32, IEC34, CSA C22.2-100, AS1359.
- Self-ventilated and drip-proof of IP23 construction.
- Superior voltage waveform from a 2/3 pitch wound stator.
- Sustained short circuit current of up to 300% of the rated current for up to 20 sec.

Specifications	Alternator
Type	4 Pole
Exciter type	Brushless
Leads, quantity type	12, Reconnectable
Voltage regulator	DSR
Insulation	
- Material	Class H
- Temperature rise, Prime	125°C
Bearing: quantity, type	1, Sealed
Coupling	Flexible Disc
Voltage regulation	+/- 1%
Voltage rating, V	
- KE20	415
- KES20	240
Standby at 163°C, kVA	22
Prime at 125°C, kVA	20
Direct axis subtransient reactance (X"d), %	
- KE20	8.92
- KES20	9.85

Application Data

Engine

Engine specifications	
Engine model	G20
Engine type	Natural Aspiration
Cylinder arrangement	3, inline
Displacement, L (cu. in.)	2.15 (131.2)
Bore and stroke, mm (in.)	91 x 110 (3.58 x 4.33)
Compression ratio	17.5
Piston speed, m/min. (ft./min.)	330 (1082)
Rated rpm	1500
Max. power at rated rpm, kWm (BHP)	22 (29.6)
Governor: type	Mechanical
Frequency regulation, no-load to full load	ISO 5%
Frequency regulation, steady state	+/- 2.5%
Frequency, Fixed, Hz	50
Air cleaner type, all models	Dry

Exhaust

Exhaust System	
Exhaust Manifold type	Dry
Exhaust flow at rated kW, kg/hr	96.5
Exhaust temperature at rated kW, dry exhaust, °C (°F)	550 (1022)
Maximum allowable back pressure, kPa (in. Hg)	6 (1.77)
Exhaust outlet size at engine hookup, mm (in.)	40 (1.57)

Engine Electrical

Engine Electrical System	
Battery charging alternator	12 Volt
Ground (negative/positive)	Negative
Volts, VDC	12
Amps, Ah	20
Battery type - sealed maintenance free (PLT)	
- Qty.	1
Battery voltage, VDC	12

Fuel

Fuel System	
Fuel supply line, min. ID, mm (in.)	4 (0.15)
Fuel return line, mm. ID, mm (in.)	6 (0.23)
Fuel prime pump	MICO/Bosch
Fuel filter: quantity, type	1, Dual element
Recommended fuel	#2 Diesel
Fuel tank capacity, L	93

Lubrication

Lubricating System	
Type	Full pressure
Oil pan capacity, L (qt.)	5 (5.3)
Oil pan capacity with filter, L (qt.)	6 (6.3)
Oil filter: quantity, type	1, Spinon

Application Data

Cooling

Radiator System

Ambient temperature, °C (°F)	50 (122)
Engine jacket water capacity, L (gal.)	4.5 (1.19)
Radiator system capacity, including engine, L (gal.)	10.9 (2.9)
Heat rejected to cooling water at rated kW, dry exhaust, kW (Btu/min.)	18.07 (1028)
Water pump type	Impeller
Fan diameter, including blades, mm (in.)	406.5 (16)
Fan, kWm (HP)	0.55 (0.75)

Operation Requirements

Air Requirements

Radiator-cooled cooling air ¹ /min (scfm)	65 (2292)
Combustion air, kg/hr	92
Heat rejected to ambient air :	
Generator, kW (Btu/min.)	2.85 (162)

Fuel Consumption

Diesel, Lph (gph) at % load	Prime Rating
100%	5.3 (1.4)
75%	4.0 (1.06)
50%	2.8 (0.74)

Exhaust Emissions

Per ISO 8178-5 mode cycle	CPCB norms
---------------------------	------------

Noise Level

Measured at 1m per CPCB norms, db(A)	71.4
--------------------------------------	------

Controller

Standard Features and Accessories

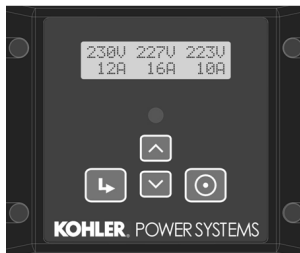

Advance Digital Control (ADC 2200)

Compact Controller

LCD display:

- Runtime hours
- Current
- Voltage
- Frequency
- Engine Temperature
- Engine oil pressure
- Battery V
- Kilowatt

LCD display faults:

- High engine temperature
- Low oil pressure
- Overspeed
- Over & under voltage
- Over & under frequency
- E-stop
- Auxiliary fault
- Low Fuel level
- Over Load

Display warning:

- Low battery voltage
- High battery voltage

Standard Features

- Master switch: Run/Off-Reset/Auto
- Remote two-wire start/stop capability
- Event log
- Superior electronics
- Factory-built and production-tested
- One-source responsibility for the generating system and accessories
- Automatic start with programmed cranking cycle
- Field software upgrade possibility

Environmental Specifications

- Operating temperature: -20°C to 70°C (-4°F to 158°F)
- Storage temperature: -40°C to 85°C (-40°F to 185°F)
- Humidity: 0-95% condensing

Power Requirements

- 12 or 24 VDC with fuse protection
- 250 mA @ 12 VDC
- 125 mA @ 24 VDC

Accessories

- Battery charger 12 V
- Mains sensing relay
- Earth leaking protection

Dimensions and Weights

Overall Size, L x W x H, mm (in.) 1997 x 950 x 1485 (78.6 x 37.4 x 58.5)

Wet, max., kg (lb.)

- KE20 978 (2156)
- KES20 1003 (2211)

Dry, max., kg (lb.)

- KE20 828 (1825)
- KES20 853 (1880)

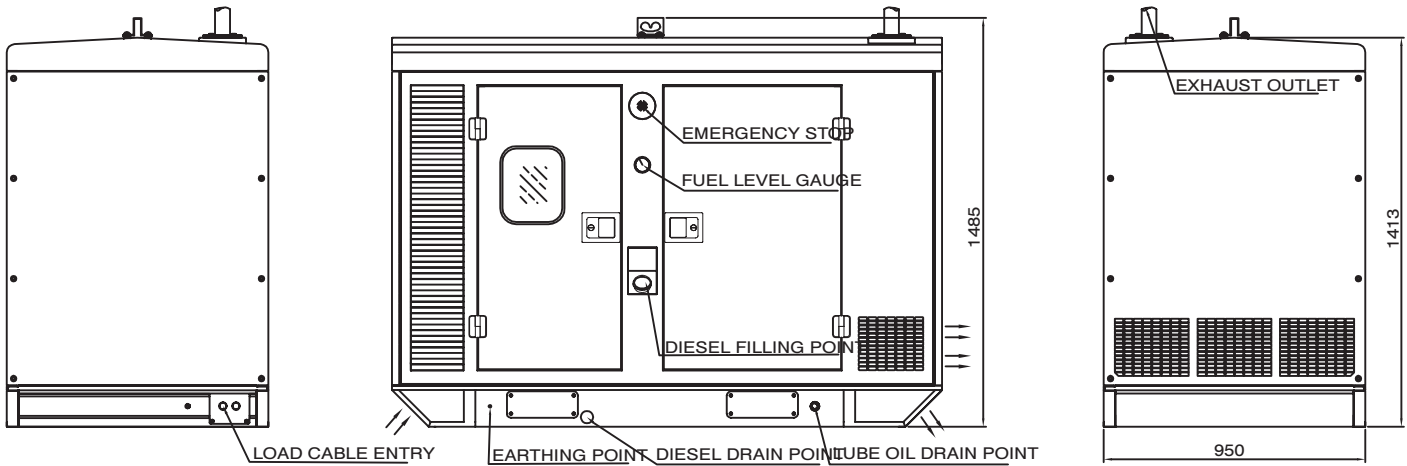
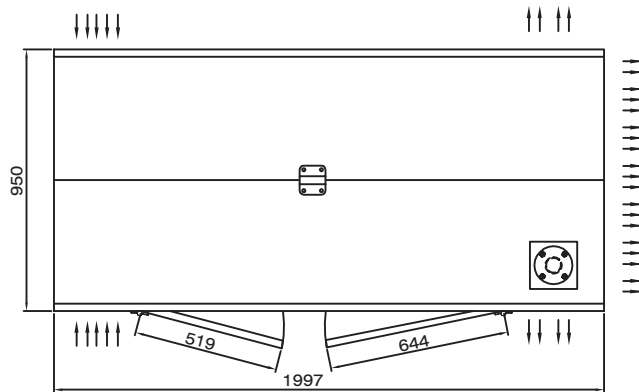

NOTE: This drawing is provided for reference only and should not be used for planning installation. Contact your local distributor for more detailed information.

DISTRIBUTED BY: